

Concentrated high intensity electric field (CHIEF) pasteurization of milk

Roger Ruan*, Shaobo Deng and Yanling Cheng

*Principal Investigator: University of Minnesota, Department of Bioproducts and Biosystems Engineering, St. Paul, MN, 55108
email: ruanx001@umn.edu

Funded by: Dairy Research Institute, November 2009–October 2010

ABSTRACT

Concentrated high intensity electric field (CHIEF) is non-thermal pasteurization technology that uses microsecond pulses of electricity to inactivate bacteria without causing undesirable changes in flavor or quality of a product. This technology was explored as an alternative to current milk pasteurization processes, and was examined for its effects on microbial stability, sensory, quality and shelf life of milk. Milk samples containing an initial inocula of approximately 10^8 CFU/mL of mixtures of *Escherichia coli* O157:H7, *Salmonella*, and *Listeria monocytogenes* or an initial inocula of 10^3 CFU/mL of viable *Bacillus cereus* spores were treated with our CHIEF system. The average (\pm standard deviation) of microbial inactivation after subjecting milk samples to a single pass through CHIEF was 2.74 (\pm 1.0), 2.95 (\pm 0.35), 2.75 (\pm 0.25), and 0.18 (\pm 0.15) log CFU/ml for *E. coli* O157:H7, *Salmonella*, *L. monocytogenes* and *Bacillus cereus*, respectively. When the milk samples were pumped twice through CHIEF, reductions of 4.36 (\pm 0.24), 5.55 (\pm 0.14), and 4.78 (\pm 0.78) log CFU/ml for *E. coli* O157:H7, *Salmonella*, and *L. monocytogenes*, respectively, were observed. Additional passes with our current system are expected to result in more bacterial reduction. These results suggest that the CHIEF process has the potential to deliver similar microbial inactivation effectiveness as a standard HTST pasteurization system.

INTRODUCTION

This project was built on R&D efforts supported through a study funded by Dairy Management, Inc. in 2007. The study demonstrated that non-thermal concentrated high intensity electric field (CHIEF) process killed *E. coli* that was inoculated in fresh milk. It also provided a better understanding of its kill effects on a broad range of pathogenic and spoilage microorganisms. Results from this study not only improved and confirmed that the CHIEF process can effectively kill pathogenic bacteria in milk, but it also helps us understand how this process effects the microbial and biological stability of milk.

During the trial experiments, milk samples containing an initial inocula of approximately 10^8 CFU/mL of mixtures of *Escherichia coli* O157:H7, *Salmonella*, and

Listeria monocytogenes were treated with CHIEF or an initial inocula of 10^3 CFU/mL of viable *Bacillus cereus* spores were treated with our CHIEF system. The average (\pm standard deviation) of microbial inactivation after subjecting milk samples to a single pass through the CHIEF device were 2.74 (\pm 1.0), 2.95 (\pm 0.35), 2.75 (\pm 0.25), and 0.18 (\pm 0.15) log CFU/ml for *E. coli* O157:H7, *Salmonella*, *L. monocytogenes* and *Bacillus cereus*, respectively.

When the milk samples were pumped twice through the CHIEF apparatus, reductions of 4.36 (\pm 0.24), 5.55 (\pm 0.14), and 4.78 (\pm 0.78) log CFU/ml for *E. coli* O157:H7, *Salmonella*, and *L. monocytogenes*, respectively, were observed. Additional passes with our current system are expected to result in more bacterial reduction. These results suggested that the CHIEF process has the potential to deliver similar microbial inactivation

effectiveness as a standard HTST pasteurization system. Improvement/optimization of the engineering aspects of CHIEF technology will certainly enhance the bacterial kill and energy efficiency. Therefore further work is needed to improve the engineering aspects of the hardware to ensure consistent reductions greater than 5 log CFU/mL of pathogenic vegetative cells and spoilage organisms.

Non-thermal pasteurization methods

There are a few non-thermal pasteurization techniques that are gaining interest in the food industry such as high hydrostatic pressure (HHP), pulsed electric fields (PEF), pulsed light, ultrasound, oscillating magnetic fields (OMF), and ionizing, irradiation (Ohlsson et al. 2002). Among these non-thermal methods, HHP and PEF have been researched extensively regarding their applications in liquid food treatment. This study examined the advantages and disadvantages of HHP and PEF processes to illustrate that the CHIEF process can be a feasible alternative to the current thermal processes.

High hydrostatic pressure (HHP)

HHP can effectively inactivate vegetative cells of microorganisms, but it alone does not achieve a substantial inactivation of spores and reduction in activity of certain enzymes (Smelt 1998; Hendrickx et al. 1998). The killing mechanism for HHP is a combination of the breakdown of non-covalent bonds and the puncturing or permeabilization of cell membranes.

HHP technology was first commercialized in Japan in the early 1990s for pasteurization of acid foods for refrigerated storage. The majority of HHP-processed products available in the market are high acid products like fruit juices or sauces (Tewari et al. 1999). These products are good candidates for HHP preservation due to their low pH, they are mainly spoiled by microorganisms that are relatively sensitive to HHP (yeast, molds, and lactic bacteria), and do not support the germination of pressure-resistant bacterial spores.

Research has suggested that HHP is more effective when combined with heat treatment (Simpson and Gilmour 1997). A significant commercial drawback of HHP technology is its prohibitively high capital investment and processing cost, and the degree to which consumers will consider the superior quality sufficient to merit a premium price. An HHP plant for fruit juice pasteurization is about 20 times the cost of an equivalent heat exchanger system. It will not be a widely accepted alternative to conventional liquid pasteurization methods in the near future. However, there is a growing interest in

producing entirely novel food products as an alternative to conventional pasteurization methods (Ohlsson et al. 2002).

Pulsed electric fields (PEF)

Microbial inactivation by PEF was first observed in the early 1960s (Doevenspeck 1961). PEF involves applications of short duration (microseconds), high-intensity electric field pulses. The key mechanisms are believed to be electroporation of membranes, and certain degrees of ohmic heating. PEF has received increased attention in the last decade as a food preservation technique because of its potential to inactivate microorganisms at temperatures below that adversely affecting food quality (Castro et al. 1993; Qin et al. 1995).

PEF is highly effective in killing vegetative cells of bacteria, yeast, and molds (Wouters and Smelt 1997). However, PEF inactivation of bacterial spores and enzymes as related to food quality is unclear. While some authors have reported the inactivation of bacterial spores (Marquez et al. 1997) and enzymes by PEF (Ho et al. 1997; Giner et al. 2000), others have observed that treatments were unsuccessful (Pagan et al. 1998; Grahl and Markl 1996).

There are a number of drawbacks of the PEF technology. First of all, ohmic heating occurs during the PEF discharge, which causes the temperature of the sample to rise, and hence a cooling system has to be in place in order to maintain a low temperature for the liquids. Therefore, a significant amount of energy is wasted in both unwanted heating and cooling the liquids. Secondly, since the electrodes have to be immersed in the liquid, they are regarded as major contamination sources to the liquid due to the erosion of electrodes during discharge.

The combinations of PEF with other preservation technologies are being investigated to increase the lethal effect of this nonthermal process and to extend its application to different liquid foods. For example, the combination of HHP with PEF has been investigated (Heinz and Knorr, 2000; Jayaram et al. 1992; Pothakamury et al. 1996; Hulsheger et al. 1981; Wouters et al. 1999). Finally the high capital cost of the pulsed power equipment is also a major obstacle for the application of the current PEF technology. The capital cost for a future commercial PEF system has been estimated to be about twice that of a corresponding thermal system (Ohlsson et al. 2002).

Non-thermal plasma (NTP)

Non-thermal plasma (NTP) is electrically energized matter in a gaseous state, and can be generated by passing gases through electric fields. The mean electron energies of NTP, which is about 20 eV, are considerably higher than those of the components of the ambient gas. During NTP generation, the majority of the electrical energy goes into the production of energetic matters rather than into gas heating.

The energy in NTP is thus directed preferentially to the electron-impact dissociation and ionization of the background gas to produce NTP species including electrically neutral gas molecules, charged particles in the form of positive ions, negative ions, free radicals and electrons, and quanta of electromagnetic radiation (photons). These species are very strong oxidizers that can rapidly decompose other inorganic and organic compounds.

The killing mechanisms of NTP are not well established. However, there are some hypotheses. It is well documented that reactive oxygen species (ROS) such as oxygen radicals can produce profound effects on cells by reacting with various macromolecules. NTP is predicted to contain these as well as many other more stable intermediates.

Among the cellular macromolecules altered are membrane lipids, which are most vulnerable macromolecule of the cell, probably because of their location near the cell surface, and their sensitivity to ROS. When the cytoplasmic membrane lipids are altered, this will result in a massive release of macromolecules, and thus death of the cells. Various resistances to NTP exposure exhibited by different microbes are correlated to the protective outer polysaccharide layer structure (or thickness) of individual microbes. Non-thermal plasma is mostly used for water and waste water treatment, surface sterilization and environmental control.

Concentrated high intensity electric field (CHIEF)

Concentrated high intensity electric field (CHIEF) is the similar technology as PEF. Both of them use high intensity electrical field to inactivate the bacteria (electroporation mechanism). Comparing with PEF technology, CHIEF has some unique characters: CHIEF is powered by low and medium frequency alternate current (AC) power instead of high frequency pulsed direct current (DC) power, which significantly reduces capital investment. CHIEF uses a non-metal (dielectric) barrier to limit electric current flow through the liquid to eliminate ohmic heating. This reduces temperature rise and avoids contaminations from metal electrodes' oxidation, corrosion, and erosion that usually occurs in conventional pulsed electric field (PEF) method. Hence,

there is no need to change the electrodes periodically. Additionally, CHIEF uses a unique configuration design which greatly improves the energy efficiency by directing voltage (electric field strength) to the liquid being treated instead of wasted in the electrodes and dielectric barriers.

Foodborne pathogens such as Salmonella, Escherichia coli O157:H7, Campylobacter and Listeria monocytogenes have been linked to gastrointestinal disease caused by raw milk and a variety of dairy products made from raw milk or contaminated post-pasteurization (Cody et al, 1999, Heuvelink et al, 1998). All of these microorganisms are known to be natural inhabitants of the gastrointestinal tract of cattle and they can be transmitted to milk during milking and milk handling.

Milk pasteurization is capable of killing all of these bacteria, but if the milk is not processed they can survive even in fermented products for relatively long time. With the increased interest by U. S. consumers for raw milk, in recent years the number of Campylobacter has been increasing (CDC, 2009).

The demand for raw milk and dairy products made from unpasteurized milk is driven by the consumers' interest in consuming minimally processed products. For many years, researchers have been searching for a non-thermal process as an alternative to traditional pasteurization, but to this date only irradiation and HPP have proven to be effective. However, high-energy irradiation is not approved for use in milk products and HPP can have some limitations discussed above.

The use of a similar technique called high-intensity pulsed-electric field (HIPEF) has been investigated for more than ten years, but it was not very effective to kill foodborne pathogens in a variety of foods (Raso and Barbosa-Canovas, 2003). Recent work has suggested that its utilization with other strategies such as another non-thermal processes and antimicrobial ingredients may be necessary. The proposed CHIEF, may offer a more effective alternative to the traditional HIPEF.

OBJECTIVES

1. Optimize the current process and CHIEF pilot system. Improve efficiency.
2. Study and confirm the effect of treatments on vegetative cells and spores of pathogenic microorganisms in milk.
3. Generate experimental data that target FDA approval.

MATERIALS AND METHODS

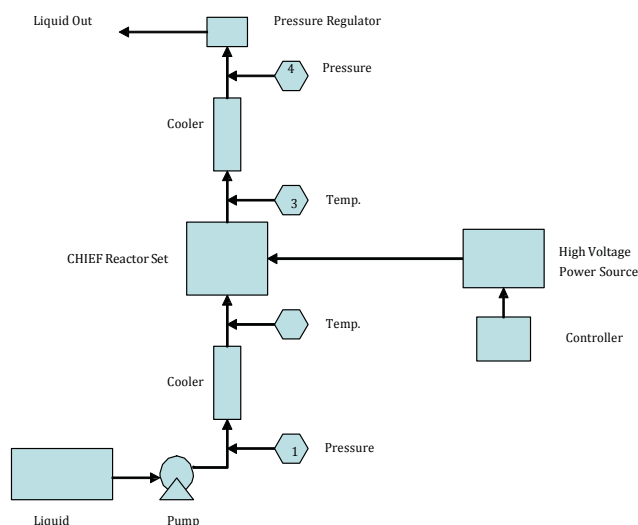

Figure 1. Diagram of CHIEF system

Small pilot CHIEF System

A new mobile continuous pilot prototype CHIEF system was designed with a capacity of 2 L/min. The process flow diagram (Figure 1) shows the reactor set consists of 2 treatment modules, with each module containing two reactors. The modules are arranged vertically and the reactors (R1-4) are connected in serial. Each module is cooled at the liquid entry and exit points. The system is used for process development and verification in the lab, and for demonstration on and off campus. The key system parameters include electrical field strength from 10 kV/cm to 70 kV /cm, flow rate from 500 to 2000 ml per minutes, and working pressure from 150 to 1500 psi. These parameters are interrelated and are discussed in further detail in the Results and Discussion section.

Milk Samples and microbial indicators

Skim milk was used as testing samples to study the effects of CHIEF treatments on bacterial reduction. Some experiments used pasteurized skim milk so that bacterial inoculation and contamination were controlled and known. Indicator organisms included Escherichia coli, Salmonella, Listeria monocytogenes and Bacillus cereus.

CHIEF Treatments

Milk (3 L) was measured and placed in a beaker in the biosafety cabinet on a magnetic stirrer. Milk was inoculated, mixed and transferred to inflow containers. CHIEF unit's parameters were adjusted to experimental protocol using the following settings: flow rates 2000

Table 1. Bacterial count of *E. coli* O157:H7 inoculated into milk before and after treatment with CHIEF.

Strain	Inoculum	Post-treatment	Population reduction
ATCC43890	5.76	< 2.00*	≥ 3.76
ATCC43895	5.94	< 2.00*	≥ 3.94
ATCC35150	5.40	< 2.00*	≥ 3.40
86-24	7.94	4.79	3.14
ATCC43890, 43895, 35150, 86-24 & 3081	8.05	4.16	3.88

* Detection limit of microbiological method was 100 CFU/mL. (Reported by Dr. Francisco Diez-Gonzalez, University of Minnesota, Department of Food Science and Nutrition)

ml/min, applied voltage 35-40kV, frequency 60 Hz, pump pressure 900-1,000psi, and backpressure 100-150 psi. Treated milk was collected in outflow containers on a biosafety cabinet, and then subjected to microbiological testing prior to and after CHIEF treatment.

Bacterial strains and inocula preparation

A total of 5 strains of Salmonella, *E. coli* O157:H7, *Listeria monocytogenes* and *Bacillus cereus* were used for milk inoculation (Table 1). Stock cultures of all the strains were stored in glycerol at -55°C. Working cultures were prepared after streaking onto tryptic soy agar (TSA), and incubated at 37°C for 48 h. A single colony was picked and transferred into tubes containing tryptic soy broth (TSB) media. Tubes were incubated at 37°C for 18 h to reach stationary phase and an approximate bacterial cell concentration to 10⁹ CFU/ml.

Cultures of the five strains used in each experiment were evenly mixed and used to inoculate 3 L of commercially available pasteurized skim milk to obtain approximately 10⁸ CFU/g. Spores of *B. cereus* were obtained by spreading liquid cultures of *B. cereus* onto new sporulation media (NSA) plates. Plates were incubated at 37°C for 2 days, and then held at room temperature for 1 day. Colonies were re-suspended in distilled water. The last step followed a previously-developed protocol from Ruan's laboratory for harvesting spores from *Bacillus anthracis*. Buffer spore suspensions were stored at 4 °C and inoculated at 10³ CFU/g into milk samples.

Microbiological methods

Bacterial counts were determined in duplicate at each of the following sampling times: milk (1 ml) was mixed

Table 2. Effect of a single-pass CHIEF treatment on viable count of pathogenic bacteria inoculated into skim milk

Bacteria	Serotype	Initial count	Final count	Reduction
		(log CFU/mL)		
<i>E. coli</i> O157:H7 (5 strain mixture)	EC	8.00	5.25	2.74
<i>Salmonella</i> (4 strain mixture)	S-N	7.93	4.86	3.07
	S-Tn	8.16	5.04	3.11
	S-Ty	8.07	5.14	2.93
<i>Salmonella</i> (5 strain mixture)	S	8.09	5.14	2.95
<i>Listeria monocytogenes</i> (5 strain mixture)	LM	7.91	5.16	2.74
<i>Bacillus cereus</i> 3 strain mixture)	BC	3.56	3.38	0.18

S-N= all *Salmonella* strains except Newport AM05104; S-Tn = all *Salmonella* strains except Tennessee; S-Ty1= all *Salmonella* strains except UK-1; S-Ty2 = all *Salmonella* strains except ATCC700804; S-Ty3= all *Salmonella* strains except ATCC14028

Table 3. Effect of a double-pass CHIEF treatment on viable count of pathogenic bacteria inoculated into skim milk

Bacteria	Serotype	Initial count	Final count	Reduction
		(log CFU/mL)		
<i>E. coli</i> O157:H7 (5 strain mixture)	ECD	7.87	3.51	4.36
<i>Salmonella</i> (5 strain mixture)	SD	7.99	2.44	5.55
<i>L. monocytogenes</i> (5 strain mixture)	LMD	8.18	3.44	4.73

Data were reported by Dr. Francisco Diez-Gonzalez, University of Minnesota, Department of Food Science and Nutrition

with 9 ml of buffered peptone water (BPW) in a vortex mixer, serially diluted 10-fold into test tubes containing BPW to 10⁻⁴. Small aliquots (0.1 ml) of each dilution (0.1 ml) was spread-plated onto the appropriate selective media (PALCAM agar for *Listeria*, XLD agar for *Salmonella*, Sorbitol MacConkey for *E. coli* O157:H7, and mannitol egg yolk -polymyxin for *Bacillus cereus*).

Petri plates were incubated at 35°C for 24-48 h. Typical colonies with black precipitate (*Listeria*), black color (*Salmonella*, or *Bacillus*) or colorless (*E. coli* O157:H7) were numbered and the final counts were calculated based on the dilution factors. Counts ranging from 5 to 10 colonies per plate were confirmed using immunoassays and biochemical tests.

RESULTS AND DISCUSSION

Optimization of CHIEF pilot system

The CHIEF system was redesigned and built with a new mobile pilot prototype with improved reactor

material and structure. The new design uses a higher pressure pump and can achieve a working voltage (electric field strength) of 70 kV, which is a key parameter for CHIEF process to kill bacteria in milk. The high pressure pump will achieve three things: (1) insure a high flow rate through the small orifice of the reactor; (2) prevent electric discharge in the liquid that would otherwise cause damage to the milk and reactor structure; and (3) reduce electrical conductivity of the treated liquid and minimizes temperature rise. A high flow rate through the reactor will provide enough pressure to bring the generated heat from CHIEF treatments quickly to the cooling stage. The target exit temperature of <60°C will provide more leverage to raise the applied voltage and electric field without causing the exit temperature to go beyond 60°C.

Treatment effects on vegetative cells and spores of pathogenic bacteria and yeast

Preliminary experimental results show that > 3 log *E. coli* O157:H7 vegetative cell reduction was achieved

with one pass treatment when the applied voltage and exit temperature were 35-40kV and <60°C, respectively. This demonstrates that the greater bacterial reduction at higher electric field was due to the increased electric field, and a combination of electric field and temperature. There is a synergetic effect between the applied electric field and temperature. Although 60°C is below the usual pasteurization temperature, it may cause stress response that results in bacteria exhaustion and reduced resistance to electric field treatment. Stress response and bacteria exhaustion are mechanisms proposed for the hurdle technology that consists of a series of minimal processes including mild heat treatment.

Confirmation of kill effects of microbes and spores

To confirm the kill effects of the CHIEF system, various mixtures of pathogenic bacteria and *B. cereus* spores were tested. Results show that a single pass achieves bacterial inactivation ranging from nearly 2 to 3.9 CFU/ml (Table 2). *Salmonella* appeared to be more sensitive and less variable to the CHIEF treatment than *E. coli* O157:H7 as their microbial reductions varied from 2.6 to 3.1 log CFU/mL. Strains of *Listeria monocytogenes* (Gram-positive bacteria) were similarly sensitive than *Salmonella* with average reductions of 2.75 (± 0.25). The CHIEF treatment was not as effective in inactivating spores of *B. cereus*, as no more than 0.35 log CFU/ml spores were inactivated by a single pass.

Serial treatments of two consecutive passes through the CHIEF system appeared to have an additive kill effect on vegetative pathogenic strains (Table 3). The final count of *Salmonella* increased almost two-fold from 2.95 to 5.55 average log CFU/mL reduction. However, this enhanced inactivation was smaller for *Listeria* and *E. coli* O157:H7. The additional pass only increased 77% and 59% killing compared to the single-pass treatment.

Conclusions

The average (\pm standard deviation) of microbial inactivation after subjecting milk samples to a single pass through the CHIEF device were 2.74 (± 1.0), 2.95 (± 0.35), 2.75 (± 0.25), and 0.18 (± 0.15) log CFU/ml for *E. coli* O157:H7, *Salmonella*, *L. monocytogenes* and *Bacillus cereus*, respectively.

When the milk samples were pumped twice through the CHIEF apparatus, reductions of 4.36 (± 0.24), 5.55 (± 0.14), and 4.78 (± 0.78) log CFU/ml *E. coli* O157:H7, *Salmonella*, and *L. monocytogenes*, respectively. These later results clearly suggest that a CHIEF treatment has potential to deliver similar microbial inactivation effectiveness as a standard HTST pasteurization system.

Further work is needed to ensure consistent reductions greater than 5 CFU/mL of pathogenic vegetative cells as well as spoilage organisms

REFERENCES

- Cody, S. H., S. L. Abbott, A. A. Marfin, B. Schulz, P. Wagner, K. Robbins, J. C. Mohle-Boetani, and D. J. Vugia. 1999. Two outbreaks of multidrug-resistant *Salmonella* serotype Typhimurium DT104 infections linked to raw-milk cheese in Northern California. *JAMA* 281:1805-1810.
- Cousin, M. A., J. M. Jay, and P. C. Vasavada. 2001. Psychrotrophic Microorganisms. In F. P. Downes and K. Ito (ed.), *Compendium of Methods for the Microbiological Examination of Foods*, 4th. ed. American Public Health Association, Washington, DC.
- Heuvelink, A. E., B. Bleumink, F. L. A. M. van den Biggelaar, M. C. Te Giffel, R. R. Beumer, and E. de Boer. 1998. Occurrence and survival of verocytotoxin-producing *Escherichia coli* O157 in raw cow's milk in the Netherlands. *J. Food Protec.* 61:1597-1601.
- Morton, R. D. 2001. Aerobic plate count. In F. Pouch Downes and K. Ito (ed.), *Compendium of Methods for the Microbiological Examination of Foods*, 4th. ed. American Public Health Association, Washinton, DC.
- Raso, J., and G. V. Barbosa-Cánovas. 2003. Nonthermal preservation of foods using combined processing techniques. *Crit. Rev. Food Sci. Nutr.* 43:265-285.